

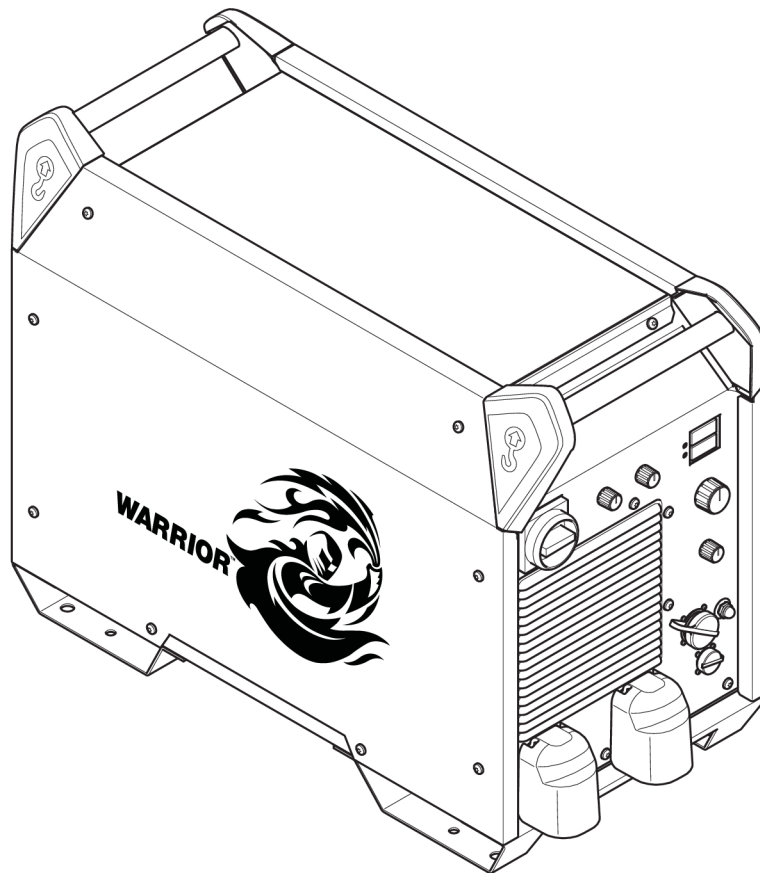

Warrior™ 750i CC/CV



Instruction manual

1	SAFETY	3
1.1	Meaning of symbols	3
1.2	Safety precautions	3
1.3	User responsibility	7
1.4	California Proposition 65 Warning.....	9
2	INTRODUCTION	10
2.1	Overview	10
2.2	Equipment	10
3	TECHNICAL DATA	11
4	INSTALLATION	13
4.1	General	13
4.2	Lifting instructions	13
4.3	Location.....	14
4.4	Main supply	14
4.4.1	Recommended fuse sizes and minimum cable area Warrior 750i CC/CV	15
4.4.2	Supply from power generators	15
4.4.3	Connection instruction	16
4.4.4	Installation of electrical cable	16
5	OPERATION	18
5.1	Overview	18
5.2	Connections and control devices	18
5.3	Connecting welding and return cables	19
5.4	Turning the power on/off	20
5.5	Fan control	20
5.6	Symbols and functions	20
6	SHIELDING GAS RECOMMENDATION	23
7	PROCEDURE FOR CAG PROCESS	24
7.1	Parallel operation of CAG process	25
8	MAINTENANCE	26
8.1	Overview	26
8.2	Power source	26
8.3	Welding torch.....	27
9	TROUBLESHOOTING	28
10	ORDERING SPARE PARTS	30
	BLOCK DIAGRAM	31
	ORDERING NUMBERS	32
	ACCESSORIES	33

1 SAFETY

1.1 Meaning of symbols

As used throughout this manual: Means Attention! Be Alert!



DANGER!

Means immediate hazards which, if not avoided, will result in immediate, serious personal injury or loss of life.



WARNING!

Means potential hazards which could result in personal injury or loss of life.



CAUTION!

Means hazards which could result in minor personal injury.



WARNING!

Before use, read and understand the instruction manual and follow all labels, employer's safety practices and Safety Data Sheets (SDSs).



1.2 Safety precautions



WARNING!

These Safety Precautions are for your protection. They summarize precautionary information from the references listed in the Additional Safety Information section. Before performing any installation or operating procedures, be sure to read and follow the safety precautions listed below as well as all other manuals, material safety data sheets, labels, etc. Failure to observe Safety Precautions can result in injury or death.



PROTECT YOURSELF AND OTHERS

Some welding, cutting and gouging processes are noisy and require ear protection. The arc, like the sun, emits ultraviolet (UV) and other radiation and can injure skin and eyes. Hot metal can cause burns. Training in the proper use of the processes and equipment is essential to prevent accidents. Therefore:

1. Wear a welding helmet fitted with a proper shade of filter to protect your face and eyes when welding or watching.
2. Always wear safety glasses with side shields in any work area, even if welding helmets, face shields and goggles are also required.
3. Use a face shield fitted with the correct filter and cover plates to protect your eyes, face, neck and ears from sparks and rays of the arc when operating or observing operations. Warn bystanders not to watch the arc and not to expose themselves to the rays of the electric-arc or hot metal.
4. Wear flameproof gauntlet type gloves, heavy long-sleeve shirt, cuffless trousers, high-topped shoes and a welding helmet or cap for protection, to protect against arc rays and hot sparks or hot metal. A flameproof apron may also be desirable as protection against radiated heat and sparks.

5. Hot sparks or metal can lodge in rolled up sleeves, trouser cuffs, or pockets. Sleeves and collars should be kept buttoned and open pockets eliminated from the front of clothing.
6. Protect other personnel from arc rays and hot sparks with a suitable non-flammable partition or curtains.
7. Use goggles over safety glasses when chipping slag or grinding. Chipped slag may be hot and can fly far. Bystanders should also wear goggles over safety glasses.



FIRES AND EXPLOSIONS

Heat from flames and arcs can start fires. Hot slag or sparks can also cause fires and explosions. Therefore:

1. Protect yourself and others from flying sparks and hot metal.
2. Remove all combustible materials well away from the work area or cover the materials with a protective non-flammable covering. Combustible materials include wood, cloth, sawdust, liquid and gas fuels, solvents, paints and coatings paper, etc.
3. Hot sparks or hot metal can fall through cracks or crevices in floors or wall openings and cause a hidden smoldering fire or fires on the floor below. Make certain that such openings are protected from hot sparks and metal.
4. Do not weld, cut or perform other hot work until the work piece has been completely cleaned so that there are no substances on the work piece which might produce flammable or toxic vapors. Do not do hot work on closed containers, they may explode.
5. Have fire extinguishing equipment handy for instant use, such as a garden hose, water pail, sand bucket, or portable fire extinguisher. Be sure you are trained in its use.
6. Do not use equipment beyond its ratings. For example, an overloaded welding cable can overheat and create a fire hazard.
7. After completing operations, inspect the work area to make certain there are no hot sparks or hot metal which could cause a later fire. Use fire watchers when necessary.



ELECTRICAL SHOCK

Contact with live electrical parts and ground can cause severe injury or death. DO NOT use AC welding current in damp areas, if movement is confined, or if there is danger of falling. Therefore:

1. Be sure the power source frame (chassis) is connected to the ground system of the input power.
2. Connect the workpiece to a good electrical ground.
3. Connect the work cable to the workpiece. A poor or missing connection can expose you or others to a fatal shock.
4. Use well-maintained equipment. Replace worn or damaged cables.
5. Keep everything dry, including clothing, work area, cables, torch/electrode holder and power source.
6. Make sure that all parts of your body are insulated from both the work piece and from the ground.
7. Do not stand directly on metal or the earth while working in tight quarters or a damp area; stand on dry boards or an insulating platform and wear rubber-soled shoes.
8. Put on dry, hole-free gloves before turning on the power.
9. Turn off the power before removing your gloves.
10. Refer to ANSI/ASC Standard Z49.1 for specific grounding recommendations. Do not mistake the work lead for a ground cable.



ELECTRIC AND MAGNETIC FIELDS

May be dangerous. Electric current flowing through any conductor causes localized Electric and Magnetic Fields (EMF). Welding and cutting current creates EMF around welding cables and welding machines. Therefore:

1. Welders with pacemakers should consult their physician before welding. EMF may interfere with some pacemakers.
2. Exposure to EMF may have other health effects which are unknown.
3. Welders should use the following procedures to minimize exposure to EMF:
 - a) Route the electrode and work cables together. Secure them with tape when possible.
 - b) Never coil the torch or work cable around your body.
 - c) Do not place your body between the torch and work cables. Route cables on the same side of your body.
 - d) Connect the work cable to the workpiece as close as possible to the area being welded.
 - e) Keep welding power source and cables as far away from your body as possible.



FUMES AND GASES

Fumes and gases can cause discomfort or harm, particularly in confined spaces. Shielding gases can cause asphyxiation. Therefore:

1. Keep your head out of the fumes. Do not breathe the fumes and gases.
2. Always provide adequate ventilation in the work area by natural or mechanical means. Do not weld, cut or gouge on materials such as galvanized steel, stainless steel, copper, zinc, lead, beryllium or cadmium unless positive mechanical ventilation is provided. Do not breathe fumes from these materials.
3. Do not operate near degreasing and spraying operations. The heat or arc can react with chlorinated hydrocarbon vapors to form phosgene, a highly toxic gas, and other irritant gases.
4. If you develop momentary eye, nose or throat irritation while operating, this is an indication that ventilation is not adequate. Stop work and take necessary steps to improve ventilation in the work area. Do not continue to operate if physical discomfort persists.
5. Refer to ANSI/ASC Standard Z49.1 for specific ventilation recommendations.



CYLINDER HANDLING

Cylinders, if mishandled, can rupture and violently release gas. A sudden rupture of cylinder valve or relief device can injure or kill. Therefore:

1. Locate cylinders away from heat, sparks and flames. Never strike an arc on a cylinder.
2. Use the proper gas for the process and use the proper pressure reducing regulator designed to operate from the compressed gas cylinder. Do not use adapters. Maintain hoses and fittings in good condition. Follow manufacturer's operating instructions for mounting regulator to a compressed gas cylinder.
3. Always secure cylinders in an upright position by chain or strap to suitable hand trucks, undercarriages, benches, wall, post or racks. Never secure cylinders to work tables or fixtures where they may become part of an electrical circuit.
4. When not in use, keep cylinder valves closed. Have valve protection cap in place if regulator is not connected. Secure and move cylinders by using suitable hand trucks.



MOVING PARTS

Moving parts, such as fans, rotors and belts can cause injury. Therefore:

1. Keep all doors, panels, guards and covers closed and securely in place.
2. Have only qualified people remove covers for maintenance and troubleshooting as necessary.
3. Keep hands, hair, loose clothing and tools away from moving parts.
4. Reinstall panels or covers and close doors when service is finished and before starting the unit.



WARNING!

FALLING EQUIPMENT CAN INJURE

- Only use lifting eye to lift unit. Do NOT use running gear, gas cylinders or any other accessories.
- Use equipment of adequate capacity to lift and support unit.
- If using lift forks to move unit, be sure forks are long enough to extend beyond opposite side of unit.
- Keep cables and cords away from moving vehicles when working from an aerial location.



WARNING!

EQUIPMENT MAINTENANCE

Faulty or improperly maintained equipment can cause injury or death.

Therefore:

1. Always have qualified personnel perform the installation, troubleshooting and maintenance work. Do not perform any electrical work unless you are qualified to perform such work.
2. Before performing any maintenance work inside a power source, disconnect the power source from the incoming electrical power.
3. Maintain cables, earthing wire, connections, power cord and power supply in safe working order. Do not operate any equipment in faulty condition.
4. Do not abuse any equipment or accessories. Keep equipment away from heat sources such as furnaces, wet conditions such as water puddles, oil or grease, corrosive atmospheres and inclement weather.
5. Keep all safety devices and cabinet covers in position and in good repair.
6. Use equipment only for its intended purpose. Do not modify it in any manner.

**CAUTION!****ADDITIONAL SAFETY INFORMATION**

For more information on safe practices for electric arc welding and cutting equipment, ask your supplier for a copy of “Precautions and Safe Practices for Arc Welding, Cutting and Gouging”, Form 52-529.

The following publications are recommended:

- ANSI/ASC Z49.1 - “Safety in Welding and Cutting”
- AWS C5.5 - “Recommended Practices for Gas Tungsten Arc Welding”
- AWS C5.6 - “Recommended Practices for Gas Metal Arc welding”
- AWS SP - “Safe practices” - Reprint, Welding Handbook
- ANSI/AWS F4.1 - “Recommended Safe Practices for Welding and Cutting of Containers That Have Held Hazardous Substances”
- OSHA 29 CFR 1910 - "Safety and health standards"
- CSA W117.2 - "Code for safety in welding and cutting"
- NFPA Standard 51B, “Fire Prevention During Welding, Cutting, and Other Hot Work”
- CGA Standard P-1, “Precautions for Safe Handling of Compressed Gases in Cylinders”
- ANSI Z87.1, "Occupational and Educational Personal Eye and Face Protection Devices"

1.3 User responsibility

Users of ESAB equipment have the ultimate responsibility for ensuring that anyone who works on or near the equipment observes all the relevant safety precautions. Safety precautions must meet the requirements that apply to this type of equipment. The following recommendations should be observed in addition to the standard regulations that apply to the workplace.

All work must be carried out by trained personnel well-acquainted with the operation of the equipment. Incorrect operation of the equipment may lead to hazardous situations which can result in injury to the operator and damage to the equipment.

1. Anyone who uses the equipment must be familiar with:
 - its operation
 - location of emergency stops
 - its function
 - relevant safety precautions
 - welding and cutting or other applicable operation of the equipment
2. The operator must ensure that:
 - no unauthorized person is stationed within the working area of the equipment when it is started up
 - no-one is unprotected when the arc is struck or work is started with the equipment
3. The workplace must:
 - be suitable for the purpose
 - be free from drafts

4. Personal safety equipment:
 - Always wear recommended personal safety equipment, such as safety glasses, flame-proof clothing, safety gloves
 - Do not wear loose-fitting items, such as scarves, bracelets, rings, etc., which could become trapped or cause burns
5. General precautions:
 - Make sure the return cable is connected securely
 - Work on high voltage equipment **may only be carried out by a qualified electrician**
 - Appropriate fire extinguishing equipment must be clearly marked and close at hand
 - Lubrication and maintenance must **not** be carried out on the equipment during operation

If equipped with ESAB cooler

Use ESAB approved coolant only. Non-approved coolant might damage the equipment and jeopardize product safety. In case of such damage, all warranty undertakings from ESAB cease to apply.

Recommended ESAB coolant ordering number: 0465 720 002.

For ordering information, see the "ACCESSORIES" chapter in the instruction manual.



WARNING!

Arc welding and cutting can be injurious to yourself and others. Take precautions when welding and cutting.



ELECTRIC SHOCK - Can kill

- Install and ground the unit in accordance with instruction manual.
- Do not touch live electrical parts or electrodes with bare skin, wet gloves or wet clothing.
- Insulate yourself from work and ground.
- Ensure your working position is safe



ELECTRIC AND MAGNETIC FIELDS - Can be dangerous to health

- Welders with pacemakers should consult their physician before welding. EMF may interfere with some pacemakers.
- Exposure to EMF may have other health effects which are unknown.
- Welders should use the following procedures to minimize exposure to EMF:
 - Route the electrode and work cables together on the same side of your body. Secure them with tape when possible. Do not place your body between the torch and work cables. Never coil the torch or work cable around your body. Keep welding power source and cables as far away from your body as possible.
 - Connect the work cable to the workpiece as close as possible to the area being welded.



FUMES AND GASES - Can be dangerous to health

- Keep your head out of the fumes.
- Use ventilation, extraction at the arc, or both, to take fumes and gases away from your breathing zone and the general area.

**ARC RAYS - Can injure eyes and burn skin**

- Protect your eyes and body. Use the correct welding screen and filter lens and wear protective clothing.
- Protect bystanders with suitable screens or curtains.

**NOISE - Excessive noise can damage hearing**

Protect your ears. Use earmuffs or other hearing protection.

**MOVING PARTS - Can cause injuries**

- Keep all doors, panels, guards, and covers closed and securely in place.
- Have only qualified people remove covers for maintenance and troubleshooting as necessary.
- Keep hands, hair, loose clothing and tools away from moving parts.
- Reinstall panels or covers and close doors when service is finished and before starting the unit.

**FIRE HAZARD**

- Sparks (spatter) can cause fire. Make sure that there are no inflammable materials nearby.
- Do not use on closed containers.

**HOT SURFACE - Parts can burn**

- Do not touch parts bare handed.
- Allow cooling period before working on equipment.
- To handle hot parts, use proper tools and/or insulated welding gloves to prevent burns.

**WARNING!**

Do not use the power source for thawing frozen pipes.

**CAUTION!**

This product is solely intended for arc welding.

ESAB has an assortment of welding accessories and personal protection equipment for purchase. For ordering information contact your local ESAB dealer or visit us on our website.

1.4 California Proposition 65 Warning

**WARNING!**

Welding or cutting equipment produces fumes or gases which contain chemicals known in the State of California to cause birth defects and, in some cases, cancer. (California Health & Safety Code Section 25249.5 et seq.)

**WARNING!**

This product can expose you to chemicals including lead, which are known to the state of California to cause cancer and birth defects or other reproductive harm. Wash hands after use.

For more information, go to www.P65Warnings.ca.gov.

2 INTRODUCTION

2.1 Overview

The **Warrior 750i CC/CV** is a welding power source intended for arc air gouging, GMAW welding, as well as for welding with powder-filled cored wire (FCAW-S), for GTAW welding and welding with coated electrodes (SMAW).

The power sources are intended for use with the following wire feed units:

- Robust Feed PRO
- Warrior Feed 304
- Warrior Feed 404HD

ESAB accessories for the product can be found in the "ACCESSORIES" chapter of this manual.

2.2 Equipment

The power source is supplied with:

- 5-m return cable with earth clamp
- Instruction manual
- 5m power cable

3 TECHNICAL DATA

Warrior 750i CC/CV						
Working voltage	380–575 V, $\pm 10\%$, 3~ 50/60 Hz					
Mains supply S_{scmin}	5.4 MVA					
Mains supply Z_{max}	0.0319 ohm					
Primary current	380 V	400 V	415 V	440 V	460 V	575 V
I_{max} GMAW - MIG	70 A	66 A	64 A	60 A	58 A	46 A
I_{max} GTAW - TIG	55 A	52 A	50 A	47 A	45 A	36 A
I_{max} SMAW - MMA	70 A	66 A	64 A	60 A	58 A	46 A
I_{max} Gouging	70 A	66 A	64 A	60 A	58 A	46 A
No load power in energy-saving mode 6.5 min. after welding	30 W					
Setting range for all modes						
GMAW - MIG flat characteristic	16 A/15 V – 820 A/44 V 10 A/10 V–820 A/34 V 15 A/15 V–820 A/44 V 100 A/18 V–820 A/44 V					
GTAW - TIG drooping characteristic						
SMAW - MMA drooping characteristic						
Gouging						
Permissible load at GMAW						
60% duty cycle	820 A/44 V					
100% duty cycle	750 A/44 V					
Permissible load at GTAW						
60% duty cycle	820 A/34 V					
100% duty cycle	750 A/34 V					
Permissible load at SMAW						
60% duty cycle	820 A/44 V					
100% duty cycle	750 A/44 V					
Gouging						
35% duty cycle	850 A/44 V					
60% duty cycle	820 A/44 V					
100% duty cycle	750 A/44 V					
Power factor at maximum current						
GMAW	0.91					
GTAW						
SMAW						
Gouging						
Efficiency at maximum current						

Warrior 750i CC/CV	
GMAW	91%
GTAW	
SMAW	
Gouging	
Open-circuit voltage without VRD function (RMS/Peak)	61/94 V DC
Operating temperature	14 to 104 °F (-10 to 40 °C)
Transport temperature	-4 to 131°F (-20 to 55°C)
Constant sound pressure when idling	<70 dB (A)
Dimensions l × w × h	33.5×16.3×25.1 in. (850×415×637 mm)
Weight (welding power source)	231.5 lb (105 kg)
Insulation class	H
Enclosure class	IP23
Application class	S

Mains supply, $S_{sc\ min}$

Minimum short circuit power on the network in accordance with IEC 61000-3-12.

Duty cycle

The duty cycle refers to the time as a percentage of a ten-minute period that you can weld or cut at a certain load without overloading. The duty cycle is valid for 104 °F (40 °C), or below.

Enclosure class

The **IP** code indicates the enclosure class, i.e. the degree of protection against penetration by solid objects or water.

Equipment marked **IP23** is intended for indoor and outdoor use.

Application class

The symbol **S** indicates that the power source is designed for use in areas with increased electrical hazard.

4 INSTALLATION

4.1 General

The installation must be carried out by a professional.



CAUTION!

This product is intended for industrial use. In a domestic environment this product may cause radio interference. It is the user's responsibility to take adequate precautions.

4.2 Lifting instructions

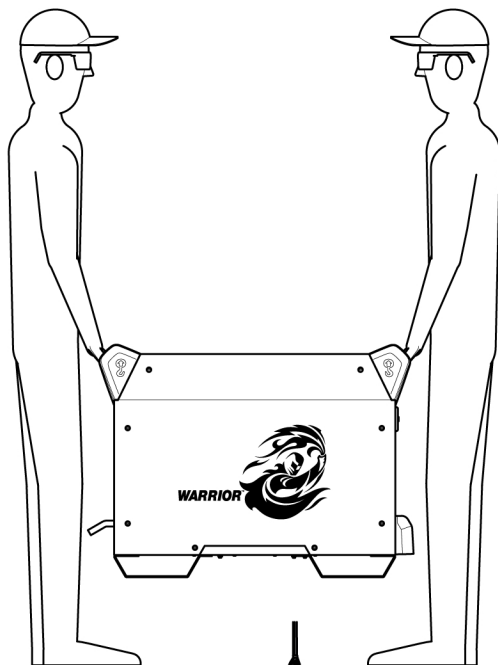

Max 115 kg/255 lb

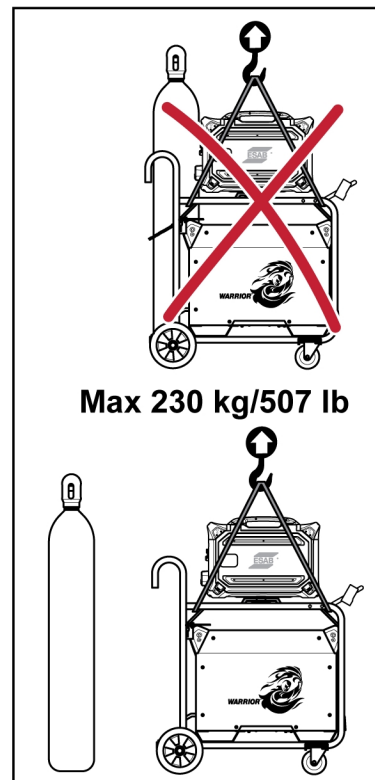
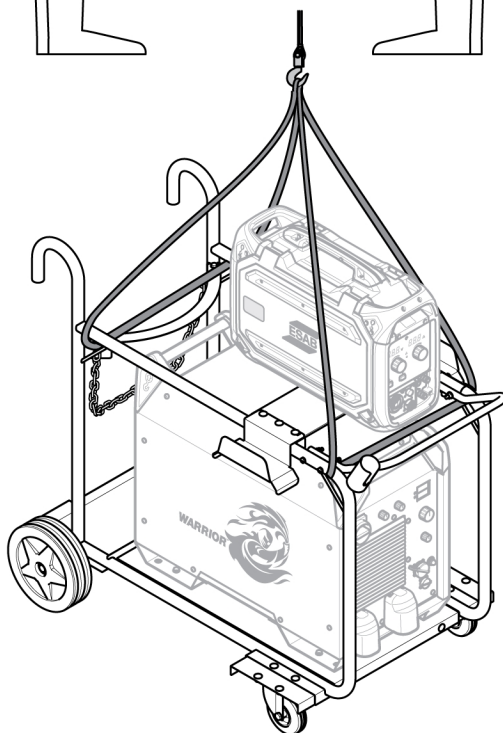
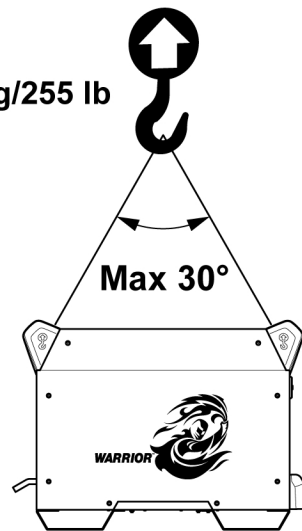

**WARNING!**

Secure the equipment - particularly if the ground is uneven or sloping.

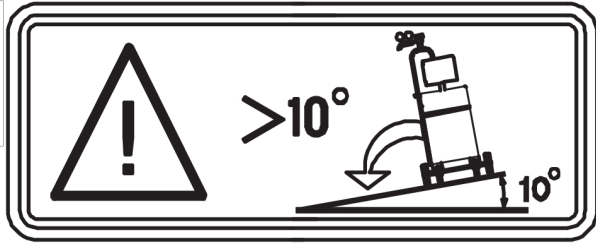

4.3 Location

Position the welding power source such that its cooling air inlets and outlets are not obstructed.

4.4 Main supply

**NOTE!****Mains supply requirements**

This equipment complies with IEC 61000-3-12 provided that the short-circuit power is greater than or equal to S_{scmin} at the interface point between the user's supply and the public system. It is the responsibility of the installer or user of the equipment to ensure, by consultation with the distribution network operator if necessary, that the equipment is connected only to a supply with a short-circuit power greater than or equal to S_{scmin} . Refer to the technical data in the TECHNICAL DATA chapter.

Make sure that the welding power source is connected to the correct supply voltage and that it is protected by the correct fuse rating. A protective ground connection must be made in accordance with regulations.

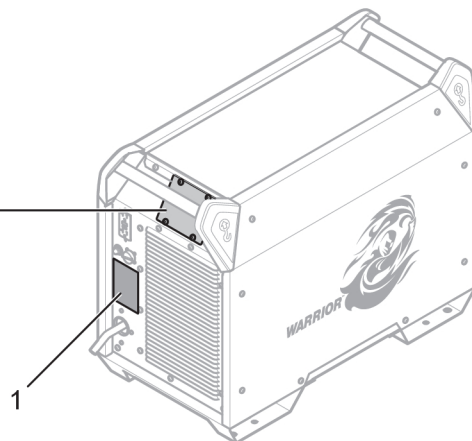
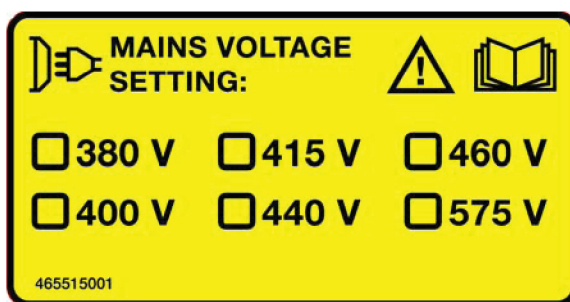

1. Rating plate with supply connection data

4.4.1 Recommended fuse sizes and minimum cable area Warrior 750i CC/CV

Warrior 750i CC/CV		
Mains voltage	380 V 3~ 50/60 Hz	400 V 3~ 50/60 Hz
Mains cable area	4×6 AWG (4×16 mm ²)	4×6 AWG (4×16 mm ²)
Phase current I_{eff}	65 A	62 A
Fuse anti-surge type C MCB	80 A	63 A

Warrior 750i CC/CV		
Mains voltage	415 V 3~ 50/60 Hz	440 V 3~ 50/60 Hz
Mains cable area	4×6 AWG (4×16 mm ²)	4×8 AWG (4×12 mm ²)
Phase current I_{eff}	60 A	56 A
Fuse anti-surge type C MCB	63 A	63 A

Warrior 750i CC/CV		
Mains voltage	460 V 3~ 50/60 Hz	575 V 3~ 50/60 Hz
Mains cable area	4×8 AWG (4×12 mm ²)	4×8 AWG (4×12 mm ²)
Phase current I_{eff}	54 A	43 A
Fuse anti-surge type C MCB	63 A	63 A



NOTE!

The power cable areas and fuse sizes as shown above are in accordance with Swedish regulations. Use the power source in accordance with the relevant national regulations.

4.4.2 Supply from power generators

The power source can be supplied from different types of generators. However, some generators may not provide sufficient power for the welding power source to operate correctly. Generators with Automatic Voltage Regulation (AVR) or with an equivalent or better type of regulation, with rated power ≥ 75 kW, are recommended.

4.4.3 Connection instruction

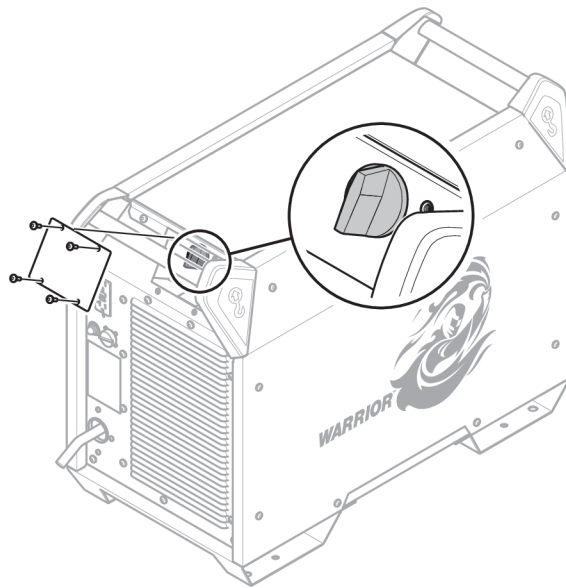

The power source Warrior 750i CC/CV (0445 555 881) for North America is connected to 460 V from the factory.

If a different voltage is required, switch off the mains, then remove the cover plate, and the selector switch can be positioned for the required voltage.

4.4.4 Installation of electrical cable

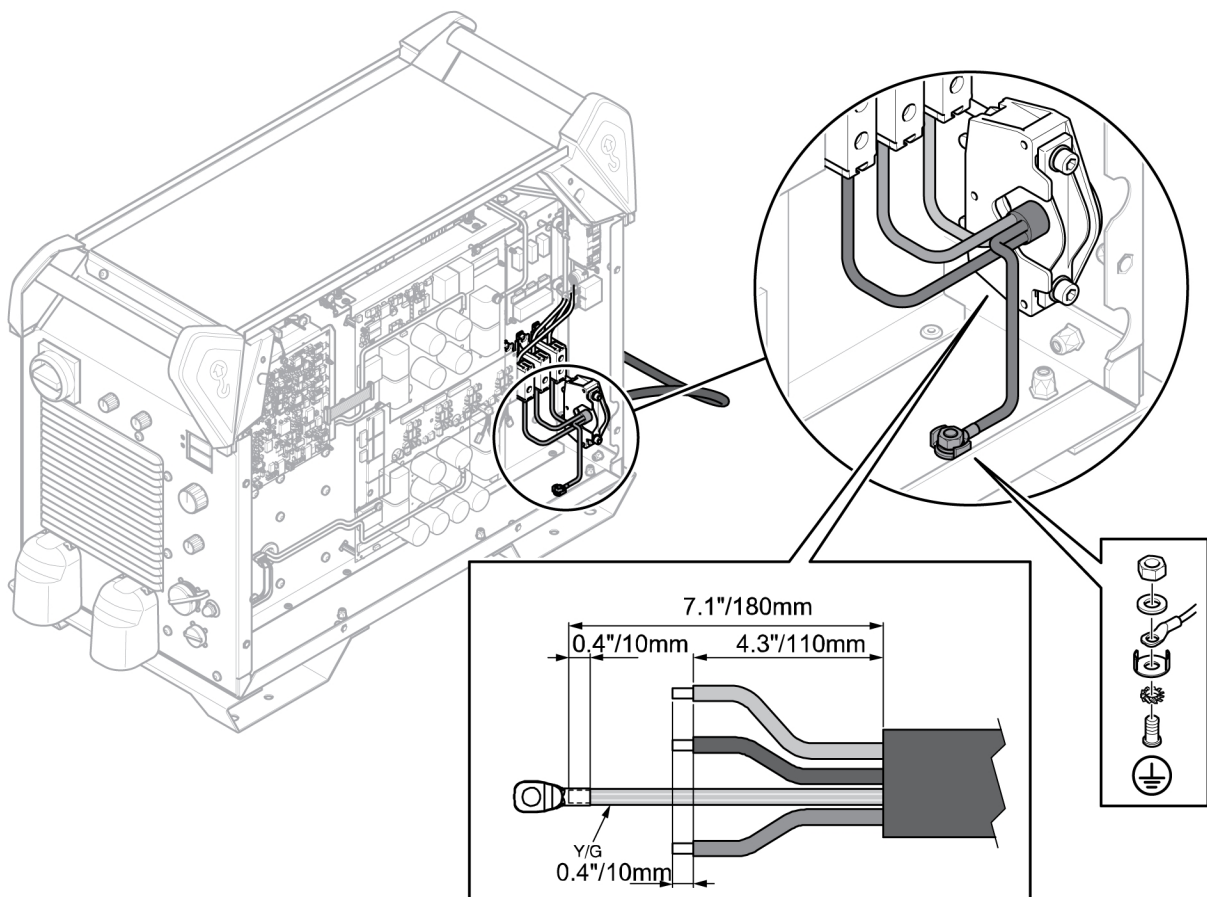

4 INSTALLATION

A mains cable needs to be installed. It is important that the ground connection to the bottom plate then be made in the correct way. See the picture above, for the placement order of the washers, nuts and screws.

5 OPERATION

5.1 Overview

General safety regulations for handling the equipment can be found in the chapter "Safety." Read it before you start using the equipment.

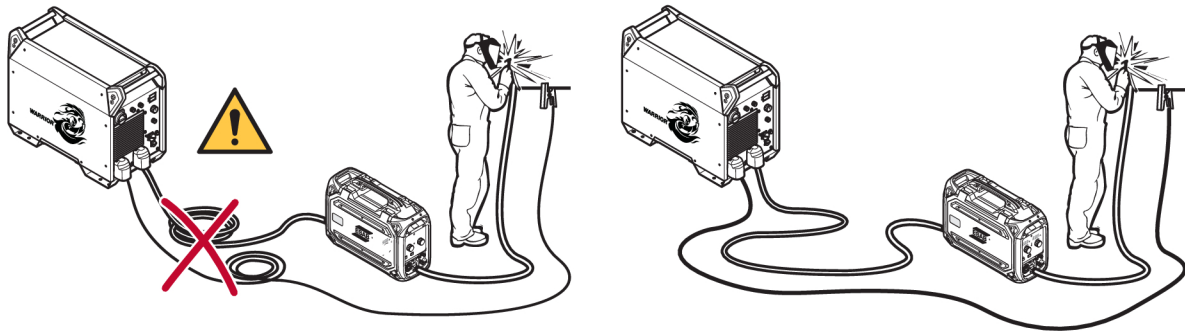

5.2 Connections and control devices

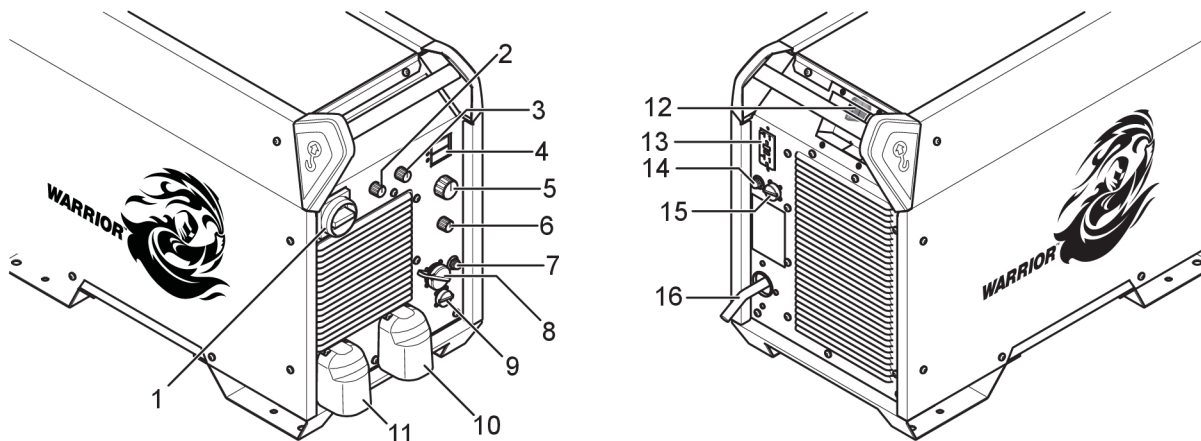

- | | |
|--|---|
| 1. Mains power supply switch, I/O | 9. Connection for remote control unit |
| 2. Knob for selecting electrode type | 10. Lug connection (-): MIG/MAG: Return cable
TiG: Welding torch
MMA: Welding cable or return cable
Gouging: Return cable |
| 3. Knob for inductance (MIG/MAG) and arc force (MMA) | 11. Lug connection (+): MIG/MAG: Welding cable
TiG: return cable
MMA: Welding cable or return cable
Gouging: Welding torch |
| 4. Display, current (A) and voltage (V) | 12. Voltage selector switch |
| 5. Knob for setting: SMAW/GTAW: current (A) and Gouging: voltage (V) | 13. Power socket for grinding machine, CO ₂ heater, lighting (115 VAC) |
| 6. Process selection knob (SMAW, GMAW, GTAW, Mobile feed, Gouging) | 14. Circuit breaker, 20 A, 115 VAC |
| 7. Circuit breaker, 10 A, 42 V | 15. Connection for cooler power supply |
| 8. Connection for wire feed unit | 16. Connection for mains power supply |

**NOTE!**

Welding terminals, positive (+) and negative (-), are lug type connectors and adapter cables are required to connect lug to OKC for 70 mm² and 95 mm² cables.

**NOTE!**

Auxiliary transformer external supply (115 V AC). Neutral not bonded to PE.

5.3 Connecting welding and return cables

The power source has two outputs, a positive terminal (+) and a negative terminal (-), for connecting welding and return cables. The output to which the welding cable is connected depends on the welding method or type of electrode used.

Connect the return cable to the other output on the power source. Secure the return cable's contact clamp to the workpiece, and make sure that there is a good contact between the workpiece and the output for the return cable on the power source.

For SMAW welding, the welding cable can be connected to the positive terminal (+) or negative terminal (-), depending on the type of electrode used. The connection polarity is stated on the electrode packaging.

Recommended maximum current values for connection cables set

At an ambient temperature of +25°C and a normal 10-minute cycle:

Cable area	Duty cycle			Voltage loss / 10 m
	100%	60%	35%	
0.08 in ² (50 mm ²)	280 A	310 A	370 A	0.35 V / 100 A
0.11 in ² (70 mm ²)	350 A	400 A	480 A	0.25 V/100 A
0.15 in ² (95 mm ²)	430 A	500 A	600 A	0.19 V/100 A
0.19 in ² (120 mm ²)	500 A	580 A	720 A	0.15 V/100 A
2×70 mm ²	700 A	800 A	960 A	0.25 V/100 A

Use additional cables in parallel if the current-carrying capacity of the cable presented in the table is exceeded.

At an ambient temperature of +40°C and a normal 10-minute cycle:

Cable area	Duty cycle			Voltage loss / 10 m
	100%	60%	35%	
0.08 in ² (50 mm ²)	250 A	270 A	320 A	0.37 V/100 A
0.11 in ² (70 mm ²)	310 A	350 A	420 A	0.27 V/100 A
0.15 in ² (95 mm ²)	370 A	430 A	520 A	0.20 V/100 A
0.19 in ² (120 mm ²)	430 A	510 A	620 A	0.16 V/100 A
2×95 mm ²	740 A	860 A	1040 A	0.20 V/100 A

Use additional cables in parallel if the current-carrying capacity of the cable presented in the table is exceeded.

Duty cycle

The duty cycle refers to the time as a percentage of a ten-minute period that you can weld or cut at a certain load without overloading.

5.4 Turning the power on/off

Turn on the mains power by turning switch to the "I" position, see 1 in the picture above.

Turn the unit off by turning the switch to the "O" position.

Whether the mains power supply is interrupted or the power source is switched off in the normal manner, the welding data will be stored so it is available the next time the unit is started.









CAUTION!



Do not turn off the power source during welding (with load).

5.5 Fan control

The power source has a time control, this means that the fans continue to run for 6.5 minutes after welding has stopped, and the power source switches to energy-saving mode. The fans start again when welding restarts.

5.6 Symbols and functions

	Location of lifting eye	VRD	Voltage Reducing Device
	Overheating protection	Basic	Basic electrode
Rutile	Rutile electrode	Cel	Cellulosic electrode
	Arc force		Inductance
	TIG welding (Live TIG)		Arc air gouging

	MMA welding		MIG/MAG welding
 Mobile Feed CV	Wire feed unit Mobile feed CV (Constant voltage)		Protective ground

Overheating protection

The welding power source has overheating protection that trips if the temperature becomes too high. When this occurs, the welding current is interrupted and an overheating indication lamp is lit.

The overheating protection resets automatically when the temperature has fallen back to the normal working temperature range.

Arc force

The arc force is important in determining how the current changes in response to a change in the arc length. A lower value gives a calmer arc with less spatter.

It only applies to SMAW welding.

Inductance

Higher inductance results in a wider weld pool and less spatter. Lower inductance produces a harsher sound, but a stable, concentrated arc.

It only applies to GMAW welding.

GTAW welding

GTAW welding melts the metal of the workpiece, using an arc struck from a tungsten electrode that does not itself melt. The weld pool and electrode are protected by shielding gas.

"Live TIG-start"

At a "Live TIG-start", the tungsten electrode is placed against the workpiece. When the electrode is lifted away from the workpiece, the arc is struck at a limited current level.



For GTAW welding, the welding power source must be supplemented with:

- a TIG torch with gas valve
- Argon gas cylinder
- Argon gas regulator
- Tungsten electrode

Arc air gouging

For arc air gouging, a special electrode is used comprised of a carbon rod with a copper casing.

An arc is formed between the carbon rod and the workpiece, which melts the material. Compressed air is supplied, so the melted material is blown away.

For arc air gouging the power source must be supplemented with:

- ARCAIR torches
- compressed air
- Return cable with clamp

**NOTE!**

The minimum and maximum settings are starting points for the rods indicated; with relatively clean metal, an acceptable gouge groove should be expected. These specific recommendations are based on the result of tests carried out on A36/ASME mild steel.

For different types of metal, adjust the volt setting and air flow for better performance.

For any gouging issues other than performance, see the TROUBLESHOOTING section.

SMAW welding

SMAW welding may also be referred to as welding with coated electrodes. Striking the arc melts the electrode, and its coating forms protective slag.

For SMAW welding, the power source must be supplemented with:

- Welding cable with electrode holder
- Return cable with clamp

GMAW and self-shielded, cored wire welding

An arc melts a continuously supplied wire. The weld pool is protected by shielding gas.

For GMAW and self-shielded, cored wire welding, the power source must be supplemented with:

- wire feed unit
- welding torch
- connection cable between power source and wire feed unit
- gas cylinder
- Return cable with clamp

6 SHIELDING GAS RECOMMENDATION

Welding	Shielding Gas	Material	Recommended Flow Rate (l/min)
MAG	Mix Ar/CO ₂	Carbon steel	Wire Ø × 10
MAG	Mix Ar/CO ₂	Stainless steel	Wire Ø × 10
MIG	100% Ar	Aluminum	Wire Ø × 12
FCAW	Mix Ar/CO ₂	Carbon steel	Wire Ø × 12
FCAW	100% CO ₂	Carbon steel	Wire Ø × 12
FCAW	Mix Ar/CO ₂	Stainless steel	Wire Ø × 12
FCAW	100% CO ₂	Stainless steel	Wire Ø × 12
TIG DC	100% Ar	Carbon steel	Cup size or nozzle number × 1.2
TIG DC	100% Ar	Stainless steel	Cup size or nozzle number × 1.2
TIG DC	100% Ar	Stainless steel	Cup size or nozzle number × 1.2
TIG AC	100% Ar	Aluminum	Cup size or nozzle number × 1.2

The general rule to be followed for shielding gas flow rate is 10 to 12 times of the wire size. It may increase for different welding applications where higher stick out and parameters are used. When using helium mixtures, the flow rate must be 1.5 to 3 times more than with argon.

7 PROCEDURE FOR CAG PROCESS

Arc air gouging

For arc air gouging, a special electrode is used comprised of a carbon rod with a copper casing.

An arc is formed between the carbon rod and the workpiece, which melts the material. Compressed air is supplied, so the melted material is blown away.

For arc air gouging the power source must be supplemented with:

- ARCAIR torches
 - compressed air
 - Return cable with clamp
1. Measure the thickness of the metal you are about to gouge and select the electrode size appropriately. See table *"Recommended voltage setting and groove depth for ARCAIR Gouging Electrodes"*, page 24.
 2. Fix the gouging rod in the gouging torch so that the projection of the rod is around 150 mm.
 3. Set the pressure of the compressed air between 80 psi and 100 psi.
 4. Before gouging, ensure the compressed air is pointing toward the work area to ensure proper blowing.
 5. Set the voltage on the power source by referring to the gouging table in the manual or on the power source.
 6. Initiate the arc by scratching the metal with the gouging rod.
 7. Maintain the gouging rod at an angle of 30–40 degrees for most of the gouging application. A steeper angle or lower travel speed may be required when going for a deep cut.
 8. Maintain a constant travel speed for better performance
 9. After finishing gouging, the groove has to be cleaned or ground for a smooth surface.



NOTE!

To ensure the correct setting for the process, melt the copper coating on the gouging rod to the same level as the carbon rod.

Recommended voltage setting and groove depth for ARCAIR Gouging Electrodes

Electrode size	Groove depth (Min. to Max.)	Set voltage
3.2 mm (1/8")	2–3.5 mm	18.5–24 V
4 mm (5/32")	3.2–4 mm	25–32 V
4.8 mm (3/16")	3.2–6.4 mm	32–37 V
6.4 mm (1/4")	3.2–8 mm	33–38 V
7.9 mm (5/16")	4–9.5 mm	35–41.5 V
9.5 mm (3/8")	4.8–12.7 mm	35–41.5 V
13 mm (1/2")	6.4–19 mm	38–45.5 V

**NOTE!**

Field results may vary due to type of metal, compressed air supply, travel speed and operator's experience.

The minimum and maximum settings are starting points for the rods indicated; with relatively clean metal, an acceptable gouge groove should be expected. These specific recommendations are based on the result of tests carried out on A36/ASME mild steel.

For different types of metal, adjust the voltage setting and air flow for better performance.

For any gouging issues other than performance, see the TROUBLESHOOTING section.

7.1 Parallel operation of CAG process

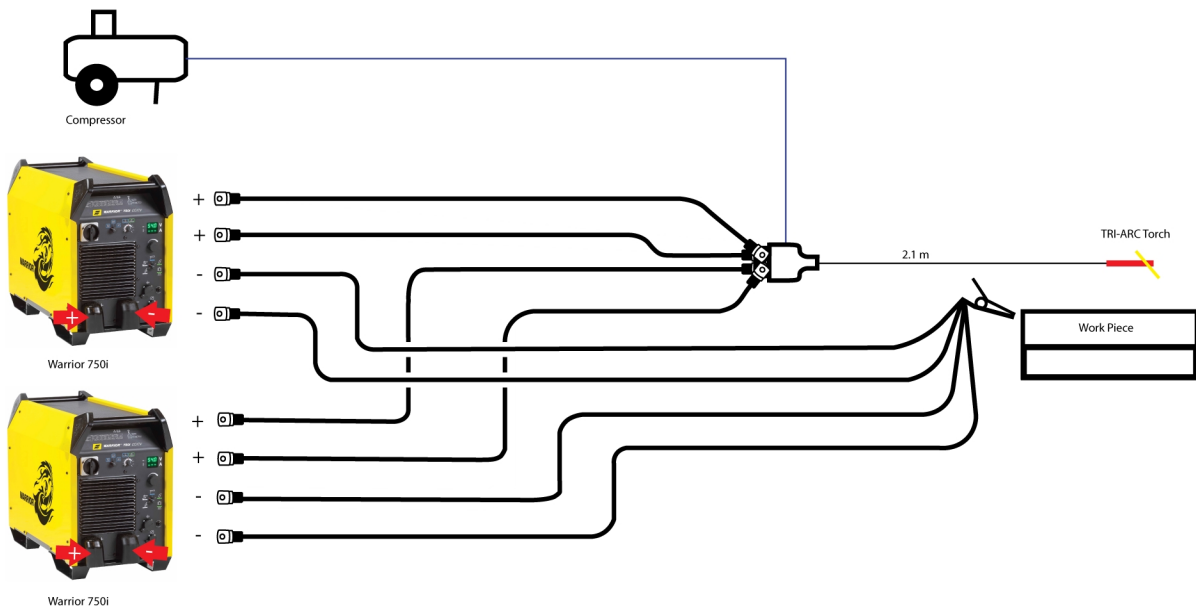

1. Connect 2×70-mm² cable for each terminal if the ambient temperature is 25°C.
2. Connect 2×95-mm² cable for each terminal if the ambient temperature is 40°C.
3. Connect +ve terminal cable to the torch and -ve terminal cable to the work piece.
4. Connect compressed gas to the torch.
5. Set equal voltage on both power sources and start gouging.

8 MAINTENANCE

8.1 Overview

Regular maintenance is important for safe, reliable operation.

Only personnel with appropriate electrical skills (authorized staff) may remove safety plates.



CAUTION!

All warranty undertakings from the supplier cease to apply if the customer attempts any work to rectify any faults in the product during the warranty period.

8.2 Power source

To maintain the performance and increase the lifetime of the power source it is mandatory to clean the product regularly. How often depends on:

- The welding process,
- The arc time, and
- The working environment.
- the surrounding environment, that is grinding etc.

Tools needed for the cleaning procedure:

- torx screwdriver, T25 and T30
- dry compressed air at a pressure of 4 bar
- protective equipment like earplugs, safety glasses, masks, gloves, and safety shoes



CAUTION!

Make sure that the cleaning procedure is done in a suitable prepared workspace.

Cleaning procedure

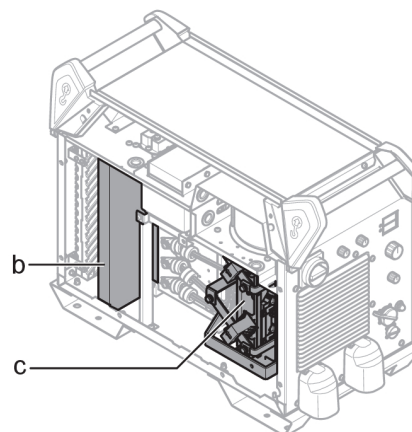
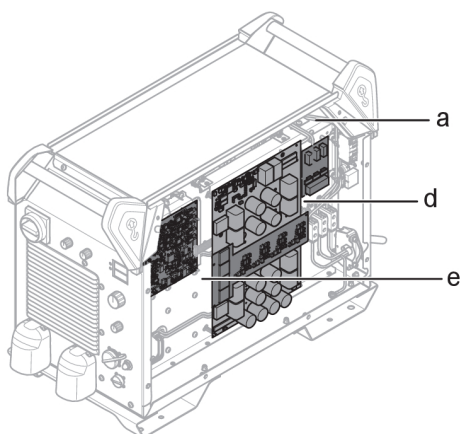

1. Disconnect the mains supply.
2. Wait for 4 minutes to discharge the capacitors.
3. Remove the side panels on the power source.
4. Remove the top panel on the power source.
5. Remove the plastic cover between the heat sink and fan (b).

6. Clean the power source with dry compressed air (4 bar) as follows:
 - a) The upper rear part.
 - b) From the rear panel through the secondary heat sink.
 - c) The inductor, transformer, and current sensor.
 - d) The power components side, from the rear side behind PCB 15AP1.
 - e) The PCBs at both sides.
7. Make sure that there is no dust left on any part.
8. Install the plastic cover between the heat sink and the fan (b) and make sure it is correctly fitted against the heat sink.
9. Install the top panel on the power source.
10. Install the side panels on the power source.
11. Connect the mains supply.

8.3 Welding torch

A regular program of care and maintenance reduces unnecessary and expensive downtime.

Each time a wire bobbin is changed, the welding torch should be removed from the power source and blown clean using compressed air.

The wire end must not have sharp edges when inserted into the wire liner.

For detailed information, see the instruction manuals for welding torches.

9 TROUBLESHOOTING

Try these recommended checks and inspections before sending for an authorized service technician.

Type of fault	Corrective action
No display.	<ul style="list-style-type: none"> • Check that the supply is available and the main switch is turned ON. • Check the supply fuses/MCB. (See the "Mains supply" section). • Press the resettable fuse near to voltage selector switch in the rear side of power source.
Overheating on welding/return cable connections.	<ul style="list-style-type: none"> • Check the electrical connections and ensure that the welding cables are tightened properly to the copper bars. • Check the size of the welding cable. (See the "Connection of welding and return cables" section.)
No arc.	<ul style="list-style-type: none"> • Check that the main power supply switch is turned on. • Check that the mains, welding, and return cables are correctly connected. • Check that the correct current value is set. • Check the electrical power supply fuses.
The welding current is interrupted during welding.	<ul style="list-style-type: none"> • Check whether the overloading protection has tripped (indicated on the front). • Check the electrical power supply fuses. • Check that the return cable is correctly fastened.
The overheating protection trips frequently.	<ul style="list-style-type: none"> • Make sure that you are not exceeding the rated data for the power source (i.e. that the unit is not being overloaded).
Poor welding performance.	<ul style="list-style-type: none"> • Check that the welding and return cables are correctly connected. • Check that the correct current value is set. • Check that the correct wire or electrode is used. • Check the electrical power supply fuses. • Check the gas pressure in the equipment connected to the power source.

Type of fault	Corrective action
"Err" on display in open circuit mode.	<ul style="list-style-type: none"> • Check the electrical power supply fuses. • Check that the voltage on the voltage selection label, on the rear of the power source, is equal to the nominal mains voltage. • Restart the power source with the main switch.
Intermittent gouging stops or contact between carbon and metal lost.	<ul style="list-style-type: none"> • Air pressure too high. Reduce the air pressure. • Check whether the air pressure is set to the recommended value. Check the manual for the torch used.
Carbon deposit on the gouge metal.	<ul style="list-style-type: none"> • Air pressure too low. Turn on the air before striking the arc; air should flow between the electrode and the workpiece. • Check whether the air pressure is set to the recommended value. Check the manual for the torch used.
No arc during start or erratic arc during gouging.	<ul style="list-style-type: none"> • Check whether the voltage is set to the recommended value.
Intermittent arc action resulting in an irregular groove surface or copper deposition on the metal plate.	<ul style="list-style-type: none"> • Check whether the voltage is set to the recommended value.

10 ORDERING SPARE PARTS



CAUTION!

Repair and electrical work should be performed by an authorized ESAB service technician. Use only ESAB original spare and wear parts.

Warrior 750i CC Warrior 750i CC/CV is designed and tested in accordance with the international standards **IEC 60974-1**, Canadian standards **CAN/CSA E60974-1:11** and US standards **ANSI/IEC 60974-1:2008**. Upon completion of service or repair work, it is the responsibility of the person(s) performing the work to ensure that the product still complies with the requirements of the above standards.

Spare parts and wear parts can be ordered through your nearest ESAB dealer, see esab.com. When ordering, please state product type, serial number, designation and spare part number in accordance with the spare parts list. This facilitates dispatch and ensures correct delivery.

BLOCK DIAGRAM

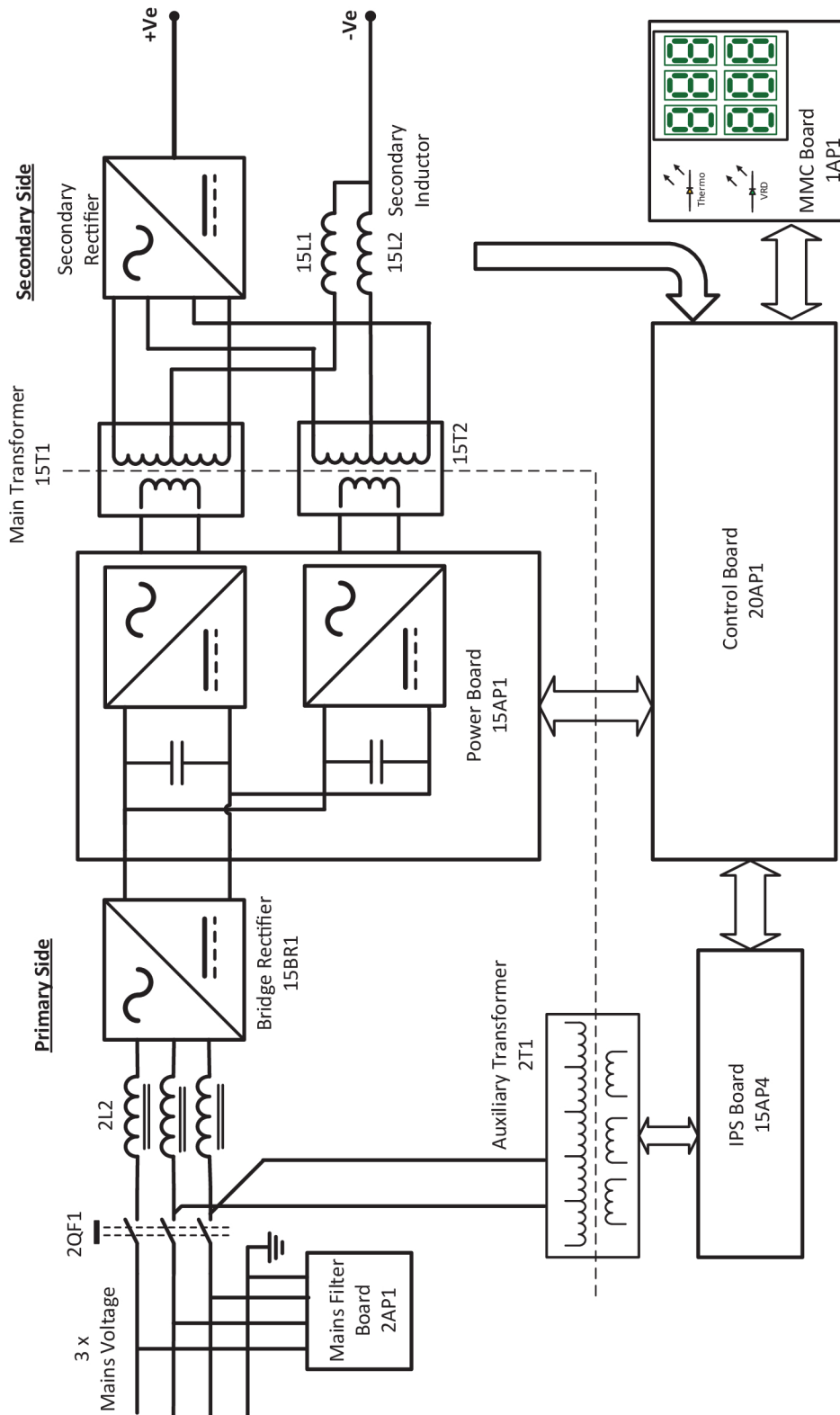



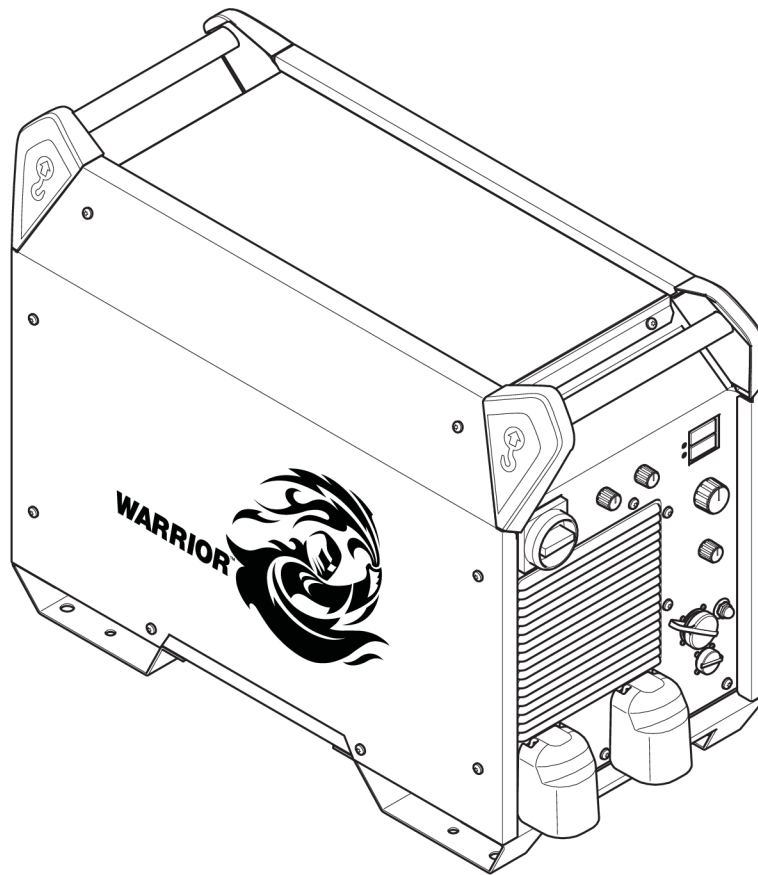

ORDERING NUMBERS





Ordering number	Denomination	Type	Notes
0445 555 881	Welding power source	Warrior 750i CC/CV	Factory set voltage: 460 VAC
0463 734 001	Spare parts list		
0463 733 001	Service manual		

Technical documentation is available on the Internet at: <http://manuals.esab.com>.

ACCESSORIES

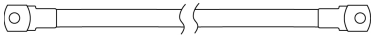
6106 5006	K3000 <ul style="list-style-type: none"> • Medium-duty general-purpose torch • Accepts 5/32" (4.0 mm) to 3/8" (9.5 mm) round electrodes and 3/8" (9.5 mm) flat electrodes • Maximum of 600 A 	
6108 2008	K4000 <ul style="list-style-type: none"> • Heavy-duty general-purpose torch • Accepts 5/32" (4.0 mm) to 1/2" (13 mm) round electrodes and 3/8" (9.5 mm) and 5/8" (16 mm) flat electrodes • Maximum of 1000 A 	
6108 4008	AirPro X4000 <ul style="list-style-type: none"> • Heavy-duty general-purpose torch • Accepts 3/16" (4.8 mm) to 1/2" (13 mm) pointed round, 3/8" (9.5 mm) and 5/8" (16 mm) flat, 5/8" (16 mm) half round • Maximum of 1000 A 	
6110 4007	K5 <ul style="list-style-type: none"> • Heavy-duty general-purpose torch • Accepts 5/16" (7.9 mm) to 1/2" (13 mm) pointed, 5/16" (7.9 mm) to 5/8" (16 mm) jointed, and 5/8" (16 mm) half round • Maximum of 1250 A 	
6299 1417	Tri ARC <ul style="list-style-type: none"> • Heavy-duty general-purpose torch • Accepts 5/16" (7.9 mm) to 1" (25 mm) round electrodes • Maximum of 2200 A 	

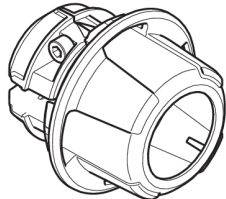

Welding cable for gouging, 95 mm²		
0413 768 897	5 m	
0413 768 898	10 m	
0413 768 899	15 m	
0413 768 880	18 m	
0413 768 881	21 m	
0413 768 882	24 m	
0413 768 883	27 m	
0413 768 884	30 m	

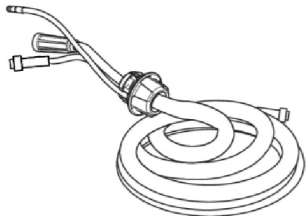

Wire feeder-Robust feed Pro		
0445 800 880	Robust Feed PRO	
0445 800 882	Robust Feed PRO, Offshore	
0445 800 884	Robust Feed PRO, Tweco	
0445 800 885	Robust Feed PRO Offshore, Tweco	
0446 050 880	Interconnection strain relief kit (for update of cables without strain relief)	

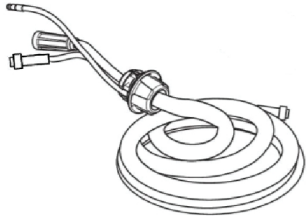
Interconnection cable with pre-assembled strain relief (Use with Robust Feed Pro)
 Must order Lug to OKC adapter along with interconnection cable set.

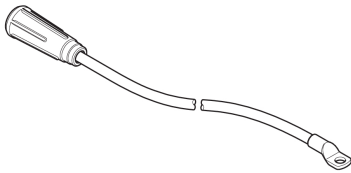
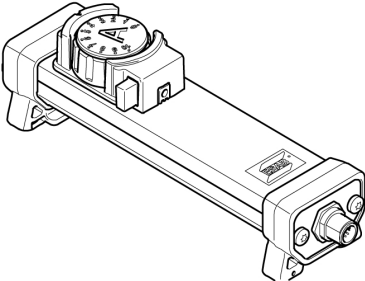
Interconnection cable set, 70 mm², 19 poles		
0446 160 880	70 mm ² , gas cooled, 2.0 m	
0446 160 881	70 mm ² , gas cooled, 5.0 m	
0446 160 882	70 mm ² , gas cooled, 10.0 m	
0446 160 883	70 mm ² , gas cooled, 15.0 m	
0446 160 884	70 mm ² , gas cooled, 25.0 m	
0446 160 885	70 mm ² , gas cooled, 35.0 m	
0446 160 887	70 mm ² , gas cooled, 20.0 m	

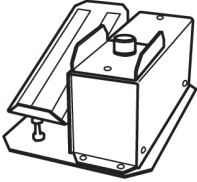
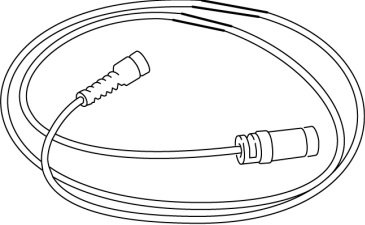
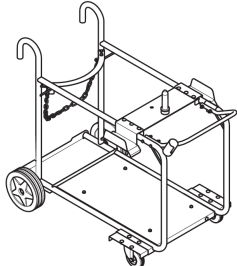
Interconnection cable set, 95 mm², 19 poles		
0446 160 980	95 mm ² , gas cooled, 2.0 m	
0446 160 981	95 mm ² , gas cooled, 5.0 m	
0446 160 982	95 mm ² , gas cooled, 10.0 m	
0446 160 983	95 mm ² , gas cooled, 15.0 m	
0446 160 984	95 mm ² , gas cooled, 25.0 m	
0446 160 985	95 mm ² , gas cooled, 35.0 m	

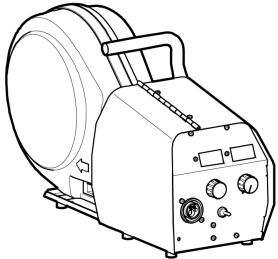
0446 507 880	Lug to OKC adapter	
0459 491 896	Remote control unit AT1 SMAW and GTAW current	
0459 491 897	Remote control unit AT1 CF SMAW and GTAW: course and fine setting of current	
0349 090 886	Foot control FS002 MMA and TIG: current	
Remote control cable, 12 pole, 8 pole		
0459 552 880	5 m	
0459 552 881	10 m	
0459 552 882	15 m	
0459 552 883	25 m	
0446 398 880	Trolley (Air cooled)	

0465 250 880	Warrior Feed 304	
0558 102 235	Warrior Feed 404 HD	

Interconnection set for Warrior Feed 304
 Must order Lug to OKC adapter along with interconnection cable set.

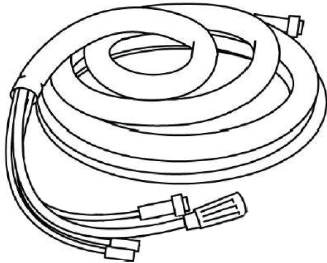
Interconnection cable set, 70 mm², 19 poles		
0459 836 880	2 m	
0459 836 881	5 m	
0459 836 882	10 m	
0459 836 883	15 m	
0459 836 884	25 m	
0459 836 885	35 m	

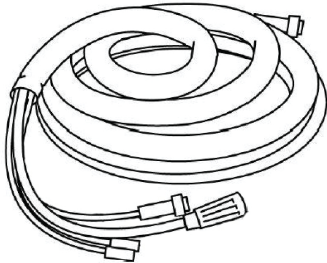
Interconnection cable set, 95 mm², 19 poles		
0459 836 980	2 m	
0459 836 981	5 m	
0459 836 982	10 m	
0459 836 983	15 m	
0459 836 984	25 m	
0459 836 985	35 m	

GTAW torches		
0700 025 530	TIG Torch SR-B 26V HD, 4 m	
0700 025 531	TIG Torch SR-B 26V HD, 8 m	



A WORLD OF PRODUCTS AND SOLUTIONS.



For contact information visit esab.com

ESAB AB, Lindholmsallén 9, Box 8004, 402 77 Gothenburg, Sweden, Phone +46 (0) 31 50 90 00

manuals.esab.com

